



BANNER / PARADE SPECIFICATIONS AND GUIDELINES

To expedite the permit process, in a timely manner please contact Lebanon Public Works Department, 60 days in advance to check banner and parade location availability. City staff will prepare required paperwork for City and ODOT applications.

BANNER LOCATIONS:

1. Santiam Hwy (between Carolina Street and Academy Street) *PPL1202PPL Pole #109601, TU131202TU Pole #109636 / PP11202PPL Pole #109640.
2. Santiam Hwy, NW corner of Maple and Park Street *TU131202TU Pole #110202, TU1311202TU Pole #1110203/PPL Pole #110202.
3. Oak Street (corner of Oak and 4th Street) TU131202TU Pole #107132 PPL1202PP1 Pole #107161.

BANNER PROVISIONS:

- The banner will be placed and removed by the City of Lebanon Maintenance Department.
- Placement duration: Limited to a display period of two weeks (14 days).
- A description of the banner, including a picture, drawing, and/or computer printout of the banner showing wording and dimensions.
- Proof of insurance. ODOT and the City of Lebanon must be named as additionally insured for \$1,000,000 liability insurance and there must be a 30-day written notice of cancellation.

BANNER SPECIFICATIONS	
SIZE:	Banners shall be 25' long and 31" tall
EYELETS:	Eyelets shall be ½" diameter (size 4) and shall be placed every 22" along the top of the banner with eyelets at each of the four corners.
ROPE:	<p>TIE-DOWN ROPE – The owner shall supply four 25-foot lengths of ½"-diameter cotton rope per banner.</p> <p>HEM ROPE – To protect the banner from being torn at the eyelets, ¼"-diameter cotton/poly rope shall be sewn into the top and bottom hems.</p>
SNAPLINKS:	The owner shall supply 16 spring snap links as shown below (shown actual size Pg.2).
OTHER:	<ul style="list-style-type: none"> • All banners shall be vented. • Banner's must be made from a durable material and constructed to withstand wind pressure of 20 pound per square foot. • Banners shall be maintained in a neat, clean manner and in good repair.

PARADE PROVISIONS:

- Description of the parade route, parade date, time, and duration.
- Map of the parade including detour routes.
- A traffic flow plan including temporary sign placement in accordance with the Manual on Uniform Traffic Control Devices (MUTCD).
- Proof of insurance. ODOT and the City of Lebanon must be names as additionally insured for \$1,000,000 liability insurance and there must be a 30-day written notice of cancellation.

THE CITY THAT FRIENDLINESS BUILT

EXAMPLES

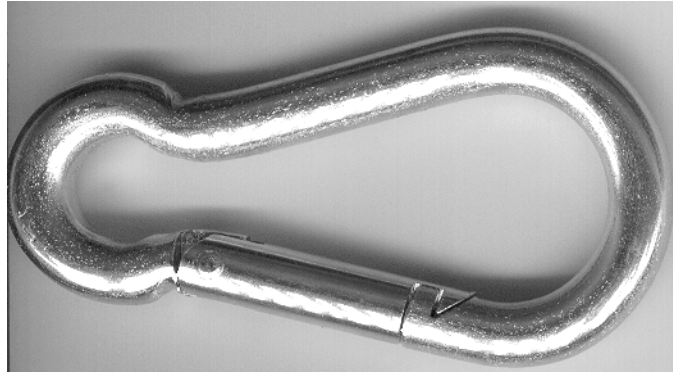

← 3½" →

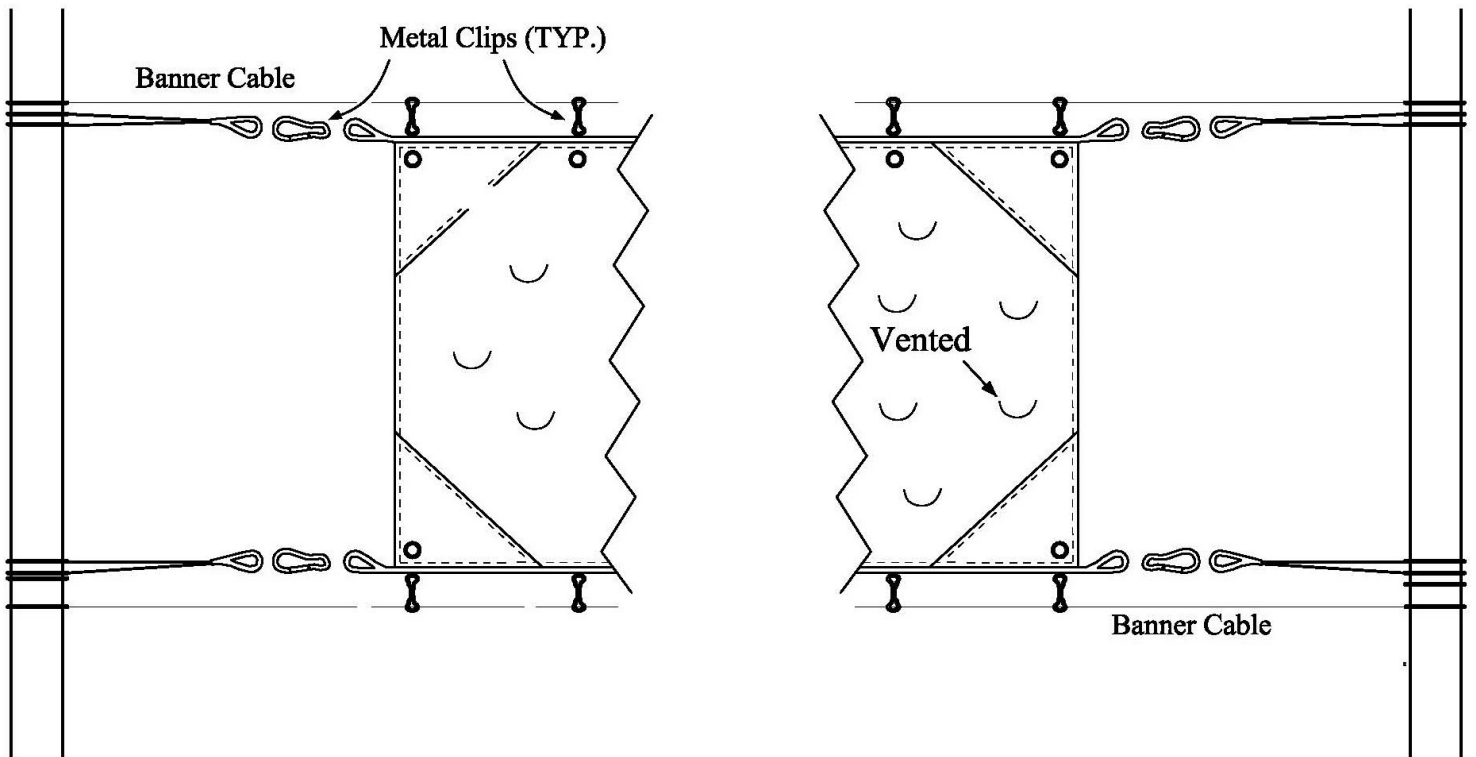

THE CITY THAT FRIENDLINESS BUILT